

MODULAR PSA NITROGEN GENERATORS

NIMOS NM3

Performance at inlet pressure: **7,5 bar (g)**

	LP					HP				
Nitrogen purity rate	95 %	97 %	98 %	99 %	99,5 %	99,9 %	99,95 %	99,99 %	99,995 %	99,999 %
Residual oxygen	5 %	3 %	2 %	1 %	0,5 %	0,1 %	500 PPM	100 PPM	50 PPM	10 PPM
Flow m³/h ⁽¹⁾ FND	23,9	18,3	15,4	13,4	10,5	6,6	6,0	4,2	3,3	2,2
Feed Air m³/h FAD	53,3	46,5	42,9	40,7	36,4	31,4	27,1	26,0	24,9	23,7

(1) Flow rates at standard atmospheric conditions (20°C/1000 mbar/0% RH) - Nitrogen outlet pressure 6bar(g) - Performance data ± 5%

Performance at inlet pressure: **9,5 bar (g)**

	LP					HP				
Nitrogen purity rate	95 %	97 %	98 %	99 %	99,5 %	99,9 %	99,95 %	99,99 %	99,995 %	99,999 %
Residual oxygen	5 %	3 %	2 %	1 %	0,5 %	0,1 %	500 PPM	100 PPM	50 PPM	10 PPM
Flow m³/h ⁽¹⁾ FND	30,1	22,7	19,0	16,2	12,6	8,2	7,5	5,3	4,2	2,4
Feed Air m³/h FAD	66,0	57,2	57,2	49,9	44,4	39,8	39,0	31,5	30,3	28,5

(1) Flow rates at standard atmospheric conditions (20°C/1000 mbar/0% RH) - Nitrogen outlet pressure 6bar(g) - Performance data ± 5%

Feed Air Requirements

Quality:	Class 1-4-1 ISO 8573.1 Solid < 0,1 µm Dew point < +3°C Oil < 0,01 mg/m ³
Pressure:	6 - 10 bar (g)
Temperature:	+5..... +45°C

⁽²⁾ Dew point at atmospheric pressure.

⁽³⁾ Necessary for guarantee performance of the nitrogen generator.

Nitrogen Specifications

Outlet pressure:	0-9 bar(g)
Dew point: ⁽²⁾	< 40°C
Nitrogen process tank: ⁽³⁾	25 lt

Power Requirements

Power Supply:	230 V / 50 - 60 Hz
Power Consumption:	max. 0,5 kW



MODULAR PSA NITROGEN GENERATORS

NIMOS NM3

Dimensions & Weight

L:	460 mm
P:	1133 mm
H:	1500 mm
Weight:	260 kg

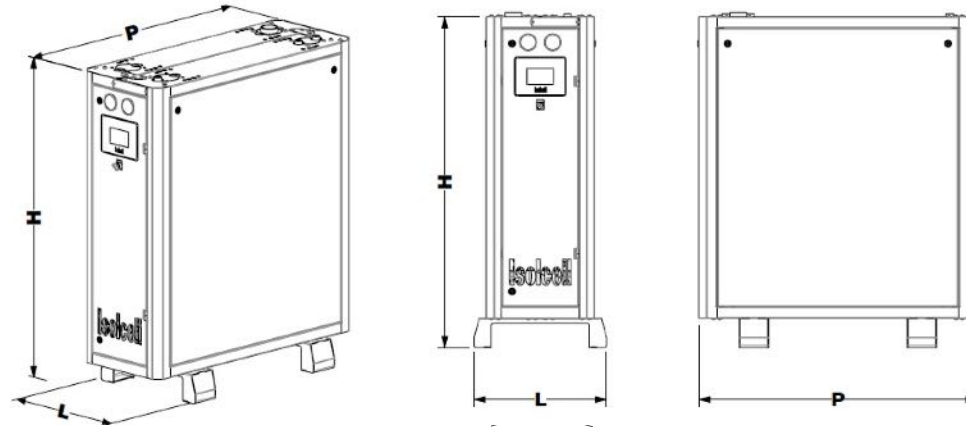

Connections

Air inlet:	G1/2"
N ₂ outlet:	G1/2"
O ₂ enriched air outlet:	G2"

STANDARD EQUIPMENT AND OPTIONS

- = standard equipment
- = option

Control panel

4 line display	●
----------------	---

Purity monitoring and control

O ₂ Electrochemical Sensor 0-25 %	○
O ₂ Zirconium Sensor 0-25 %	○
O ₂ Zirconium Sensor 10-1000 ppm	○
Dew point sensor with indication on display	○
Flow meter with indication on display	○

Valves and accessories

Back pressure control valve kit	○
Compressed air pressure sensor	○
Nitrogen buffer pressure sensor	●
Process tank pressure sensor	○
Exhaust silencer	●
Super exhaust silencer extern mounted	○

Logging and data handling

Analog output 4-20mA (O ₂ level)	●
Modbus RTU	●
Modbus RS485/USB serial converter	○
Profibus connection convert	○
Canbus connection convert	○
Webserver	○
Digital remote control	○
Extern alarm digital input	●

Necessary accessory

Process tank (Integrated)	●
---------------------------	---

